

Engineered efficiency - no matter where or what



KMe Coolers
Fresh ideas from Searle

GEA Searle



GEA Searle's wide range of commercial unit coolers guarantee the continued excellence of our product range on terms of innovation, design and performance to offer the ideal cooler at a competitive price. They are the 1st choice product for their proven design and reliability, the range comes with many benefits which is often utilised across many industries the applications include small and large cold rooms and cabinets, warehouses, food storage and preparation rooms, freezers and blast freezing.

General range features

Motors & Fansets

GEA Searle selects the optimum combination of motors and fans to deliver the best performance for the cooler size and application range. All motors and fansets are verified for power input and air volume in our Research & Development department. Specific motor data details are provided in the relevant section for each cooler type.

EC

EC fansets offer the optimum in energy efficient performance combined with low noise levels and high reliability. The KEC Cooler range uses EC fansets as standard making it the most energy efficient cooler product available. Energy usage can be less than 50% of that of similar products, resulting in a product with a reduced payback period. Additional benefits include:-

- Internal motor protection
- Long service life
- High efficiency across the full operating range

For more information on EC fansets please see the back of this catalogue "Energy Efficient Fansets"

Casework

The standard GEA Searle cooler casework is white powder coated, oven cured at 180oC to provide a hard durable finish. The JG, KLe and NS coolers are manufactured using aluminium casework, while the TEC, LDF, KEC, KMe and DSR all utilise galvanised steel casing.

Blygold Coating (Optional)

GEA Searle has installed a purpose built coating facility to apply the Blygold coil protection coating to any size of coil. Blygold with stands almost all chemical vapour exposure conditions and is ideal for the following application areas :-

- Corrosive environments
- Aggressive industrial areas

The duties presented in the specification tables are nominal. Tests are conducted in accordance with EN 328 under dry conditions which allows performance to stabilise and permits measurement over a prolonged period. The wet catalogue capacities are calculated from the dry capacities using the ratios given in the Eurovent Standard 7/C/001.

Refrigeration	R404A	R134a	R507A	R407A	R407C
Capacity factor (dew point, DT1)	1.00	0.91	0.97	1.18*	1.35*
Capacity factor (mid point, DT1)	0.97	0.91	0.97	0.91	1.01
Refrigerant charge density (kg/dm ³)	0.312	0.338	0.313	0.332	0.332

*Dew point capacity factors for refrigerants with high glide apply only at the nominal rating condition. Mid point factors can be used for all conditions. Refrigerant Charge Densities based on 25% of the internal volume being liquid.



Range benefits

The GEA Searle range of commercial unit coolers combine versatility and aesthetic design with consistent performance to offer the ideal cooler at a competitive price. They are typically the 1st choice product for the following applications due to their proven design and reliability :-

- Cold rooms
- Food storage
- Food preparation
- Cool cabinets

GEA Searle coolers are approved for many supermarkets across the world and are used extensively in convenience stores, commercial refrigeration applications and many industrial & agricultural projects.

Selection software

Due to the large number of models available and the range of alternative refrigerants, selection of the optimum cooler is best performed using the latest Searle Selection Software. The software can be obtained either as a CD, direct from your GEA Searle representative or downloaded from the GEA Searle website, where it is also possible to view all brochures and installation & maintenance data.

Energy efficient

With the increasing importance of energy efficiency as part of the selection criteria, the new GEA Searle coolers utilise fansets which offer significant energy savings over traditional motor assemblies. The KEC cooler has high efficiency EC fans as standard across the range.

Assured performance

All our commercial unit coolers where applicable are certified under the Eurovent "Certify All" programme to guarantee that every unit will perform as specified.

Availability

Many of the models in the commercial unit cooler ranges are available ex-stock from your local distributor, with backup stocks held at the UK manufacturing plant centre.

Backing our beliefs

We offer 24 months warranty on all products in the range, with 24 months warranty on all KEC coolers (subject to standard Terms & Conditions of Sale and excluding corrosion through misapplication).

	Models	No fans	Configuration	Eurovent
	JG	1 - 3		
	TEC*	1 - 3		
	LDF	1 - 3		
	NS	1 - 4		
	KEC*	1 - 3		
	KMe	1 - 4		
	DSR*	1 - 4		

✓ Yes X No ○ Option

Options								Capacity kW @ 8 kTD		
Supply	EC Fans	Standard Electric Defrost	Heavy Electric Defrost	Hot Gas Defrost A/B/C/D	CO2	Fin Materials	1	10	100	
1 ph	X	✓ Kit	X	X	X	Al	0.3 - 1.6 kW			
1 ph	X	✓ Kit	X	X	X	Al Av Cu	0.5 - 3.4 kW			
1 ph	X	✓	X	X	X	Al	1.7 - 8.5 kW			
1 ph	X	✓	X	X	X	Al	1.7 - 6.9 kW			
1 ph	✓	✓	X	✓	✓	Al Av Cu	1.2 - 10.5 kW			
1 & 3ph	O	✓	✓	✓	✓	Al Av Cu	5.7 - 28 kW			
1 ph	X	✓	X	✓	✓	Al Av Cu	0.8 - 15 kW			

Note: * See page 202 for CO2 variations of these coolers

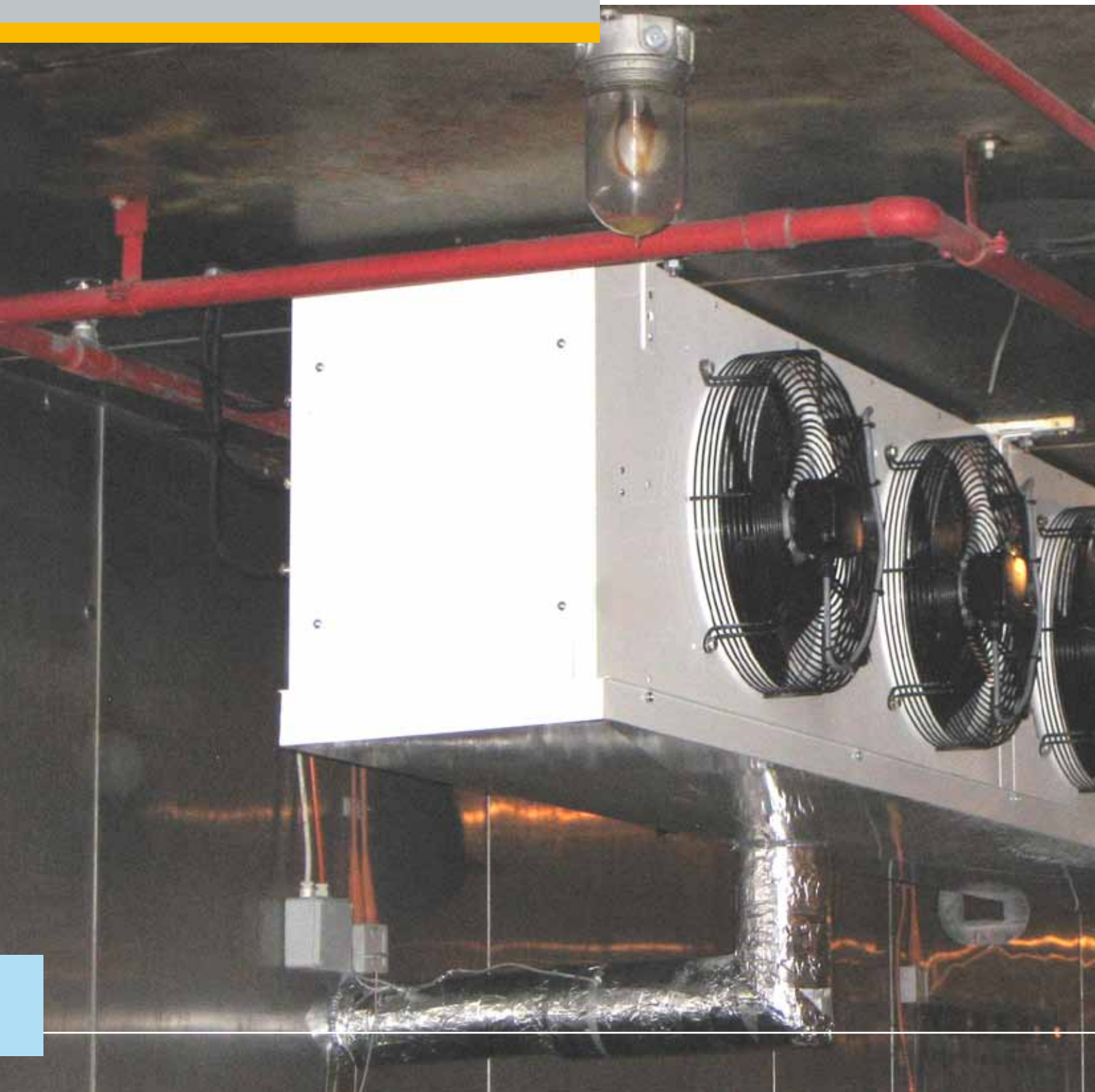

The KMe range of coolers is ideally suited to large cold rooms and small warehouses where an efficient solution is required. The KMe can also be used for industrial food processing and agricultural applications.

To find the optimum model from the range it is recommended to use the Searle Selection Software. The KMe utilises the unique GEA Searle 'D' fin which has been specifically developed for refrigeration applications. The 'D' fin utilises ½" outside diameter tube with extended inner surface – 'rifle bore' – to maximise performance. It balances the requirements of high efficiency heat transfer with the need to have secondary surface on which to deposit frost and maximise the periods between defrosts. All coils are tested to 35.8 bar and have a maximum operating pressure of 20.7 bar unless otherwise stated.

KMe Options

EC Fansets

Air streamer – to extend the air throw of the standard 400mm fanset

Forkguard – a guard system to prevent accidental damage from forklift trucks or similar when siting the cooler at low level.

Axial fans – for significantly increased air throw or for external pressure of 120Pa.

Peripheral Heaters – available in conjunction with axial fans, recommended for applications below 0°C.

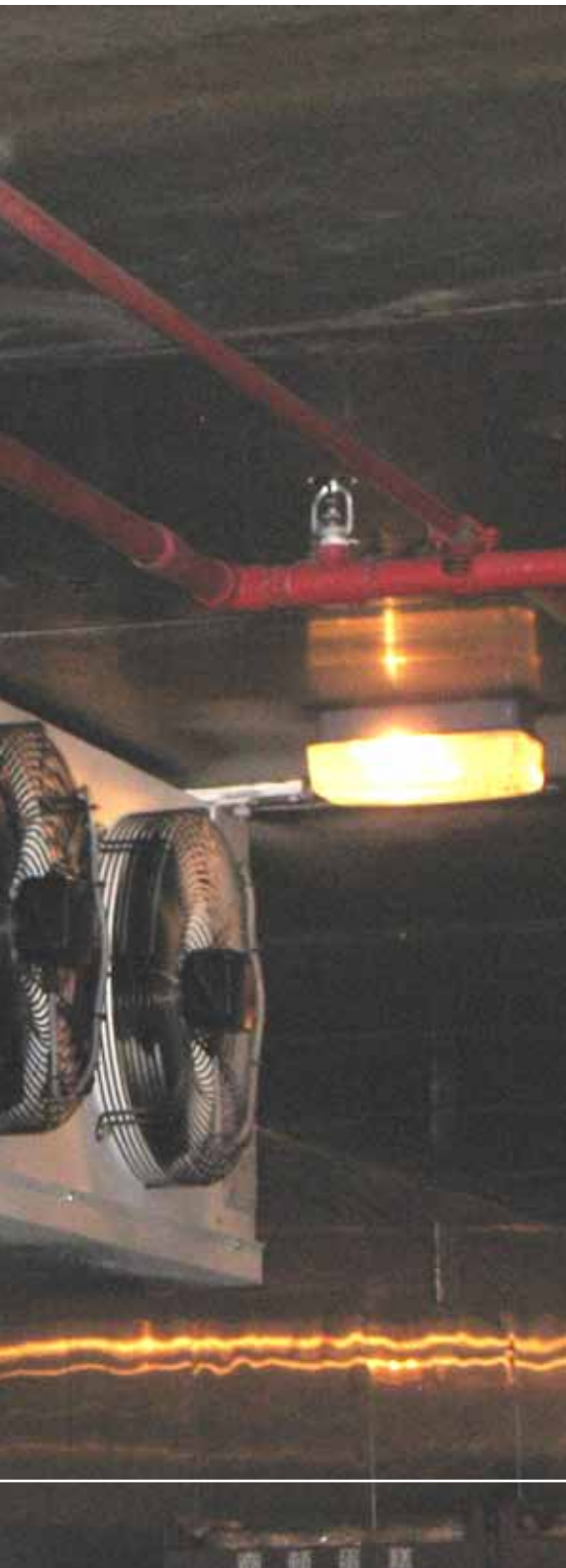

Fan plate Heaters

Heavy Electric Defrost – comprises of additional coil block heaters to increase the total defrost load by approximately 40%

Fan Plate Heaters – to prevent fan blade contact with frost build up at low temperatures.

Refrigeration	R404A	R134a	R507A	R407A	R407C
Capacity factor (dew point, DT1)	1.00	0.91	0.97	1.18*	1.35*
Capacity factor (mid point, DT1)	0.97	0.91	0.97	0.91	1.01
Refrigerant charge density (kg/dm ³)	0.312	0.338	0.313	0.332	0.332

* Capacity factors for refrigerants with high glide apply only at the nominal rating condition. Refrigerant charge densities are based on 25% of the internal volume being liquid.

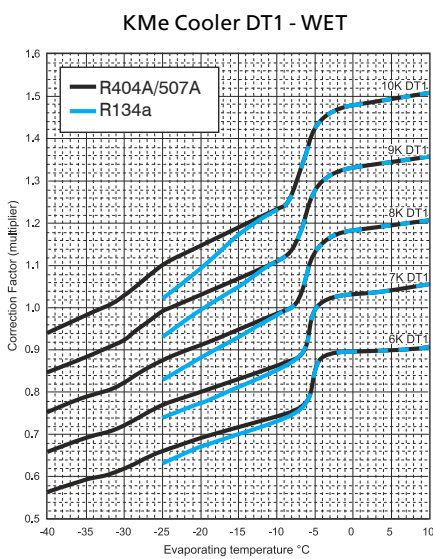

Correction Factors

(multiply capacity by appropriate correction factor to give performance at chosen conditions.



KMe 140 - 6 L - AV - 3PH - EC

Range	KEC
Model	50, 60, 80, 95, 115, 140, 175
Fin spacing	4mm, 6mm, 8mm
Defrost	Blank = No Defrost, L = Standard Electric, L2 = Heavy Duty Electric HG = Hot Gas, D = Coil & Tray / E = Electric Tray, A / B / C / D = type
Fin Material	Blank = Aluminium AV = Vinyl coated Aluminium CU = Copper
Electrical Supply	Blank = 1PH, 3PH = 3PH
Fanset Options	Blank = Standard 400mm fanset, Ax = Axial, EC = EC Fanset

Model	Capacity kW 8K DT1 (SC2)*				Air volume m ² /s	Coil data						
	R404A	R507A	R134a	R407C		Total surface area m ²	Internal volume dm ³	Ref charge kg	Connections		Dry weight kg	
									Inlet	Outlet		
4mm	KMe50-4	7.36	7.14	6.70	8.76	0.89	37.8	6.7	2.1	1/2"	1 1/8"	85
	KMe60-4	8.70	8.44	7.92	10.35	0.96	56.0	9.5	2.9	5/8"	1 1/8"	112
	KMe80-4	12.21	11.84	11.11	14.53	1.89	50.4	8.4	2.6	5/8"	1 1/8"	129
	KMe95-4	14.78	14.34	13.45	17.59	1.78	75.6	12.5	3.9	5/8"	1 1/8"	139
	KMe115-4	18.41	17.86	16.75	21.91	2.83	75.6	12.2	3.8	7/8"	1 3/8"	170
	KMe140-4	22.29	21.62	20.28	26.53	2.68	113.4	18.4	5.6	7/8"	1 3/8"	195
6mm	KMe175-4	27.92	27.08	25.41	33.22	3.45	134.4	21.6	6.6	7/8"	1 3/8"	217
	KMe50-6	6.20	6.01	5.64	7.38	0.98	25.9	6.7	2.1	1/2"	1 1/8"	83
	KMe60-6	7.45	7.23	6.78	8.87	1.01	38.3	9.5	2.9	5/8"	1 1/8"	109
	KMe80-6	9.74	9.45	8.86	11.59	2.00	34.5	8.4	2.6	5/8"	1 1/8"	126
	KMe95-6	12.50	12.13	11.38	14.88	1.95	51.8	12.5	3.9	5/8"	1 1/8"	135
	KMe115-6	14.62	14.18	13.30	17.40	3.00	51.8	12.2	3.8	7/8"	1 3/8"	166
8mm	KMe140-6	18.70	18.14	17.02	22.25	2.93	77.7	18.4	5.6	7/8"	1 3/8"	190
	KMe175-6	23.86	23.14	21.71	28.39	3.86	92.1	21.6	6.6	7/8"	1 3/8"	212
	KMe50-8	5.70	5.53	5.19	7.70	1.02	19.9	6.7	2.1	1/2"	1 1/8"	84
	KMe60-8	6.81	6.61	6.20	9.19	1.03	29.5	9.5	2.9	5/8"	1 1/8"	110
	KMe80-8	8.58	8.32	7.81	11.58	2.05	26.5	8.4	2.6	5/8"	1 1/8"	127
	KMe95-8	11.46	11.12	10.43	15.47	2.04	39.8	12.5	3.9	5/8"	1 1/8"	136
8mm	KMe115-8	12.94	12.55	11.78	17.47	3.07	39.8	12.2	3.8	7/8"	1 3/8"	167
	KMe140-8	17.19	16.67	15.64	23.21	3.06	59.7	18.4	5.6	7/8"	1 3/8"	191
	KMe175-8	21.91	21.25	19.94	29.58	4.06	70.8	21.6	6.6	7/8"	1 3/8"	212

Model	No of fans	Fan and Motor specification										Electric defrost					
		Diameter mm	Speed rpm	Air throw std/ thrower ***		Noise level ** dB(A)	230V - 1ph-50Hz			400V - 3ph-50Hz			40V - 3ph				
				4mm m	8mm m		Total power † W	F.L.C Amps per fan A	SC Amps per fan A	Total power † W	F.L.C Amps per fan A	SC Amps per fan A	Standard			Heavy duty	
													Coil W	Pan W	Total W	Coil W	Total W
KMe50	1	400	1410	17/26	19/29	60	200	1.05	3.3	200	0.65	2.6	1590	795	2385	2650	795
KMe60	1	400	1410	19/29	22/34	60	200	1.05	3.3	200	0.65	2.6	2400	1200	3600	4000	1200
KMe80	1	400	1410	19/29	22/34	63	400	1.05	3.3	400	0.65	2.6	3240	1590	4830	5400	1590
KMe95	1	400	1410	17/26	19/29	63	400	1.05	3.3	400	0.65	2.6	3240	1590	4830	5400	1590
KMe115	1	400	1410	19/29	22/34	65	600	1.05	3.3	600	0.65	2.6	4800	2400	7200	8000	2400
KMe140	2	400	1410	17/26	19/29	65	600	1.05	3.3	600	0.65	2.6	4800	2400	7200	8000	2400
KMe175	2	400	1410	17/26	19/29	66	800	1.05	3.3	800	0.65	2.6	5640	2820	8460	9400	2820

Notes:

Rating conditions:

The duties shown in this catalogue are at EN 328 Standard Condition 2 (-8°C saturated suction temperature, 0°C air entering). For data on refrigerants not shown, please contact your supplier.

* DT1 is the difference between the entering air temperature and the saturated suction temperature at the outlet of the cooler.

** Noise levels are based on free field conditions at a distance of 3m. Actual noise levels will depend upon cold store construction, store loading and the number of coolers installed.

*** Terminal air velocity 0.25m/s, free air conditions at 10°C. Air throw cannot be considered on absolute value because many factors have a substantial effect on the distance achieved.

† Total Power Input at Standard Condition 2 (-8°C saturated suction temperature, 0°C air entering).

KMe50

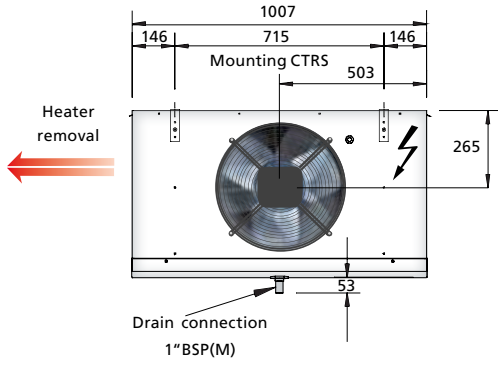

Mounting brackets details

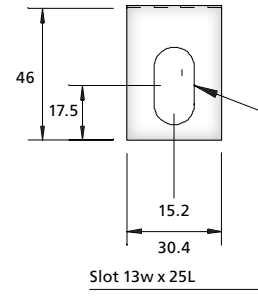

KMe 60

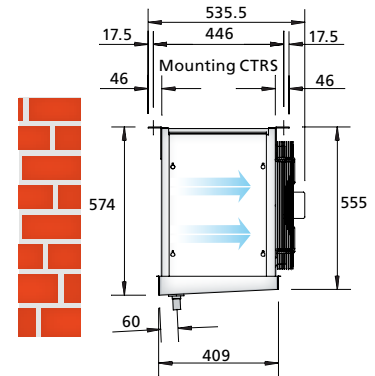
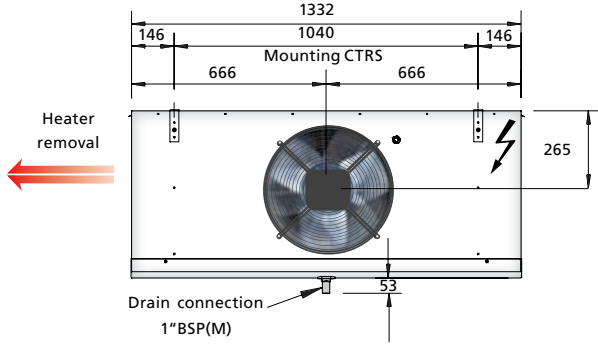

KMe80, KMe 95

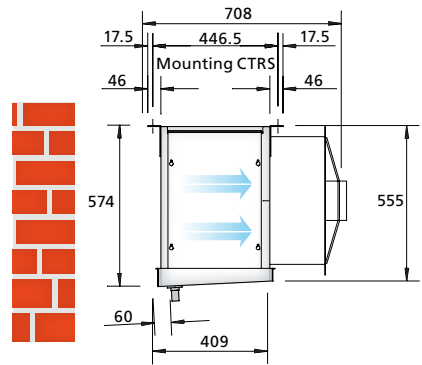
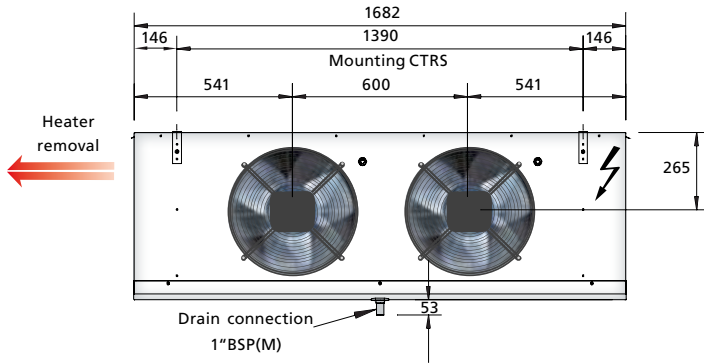

KMe 115, KMe 140

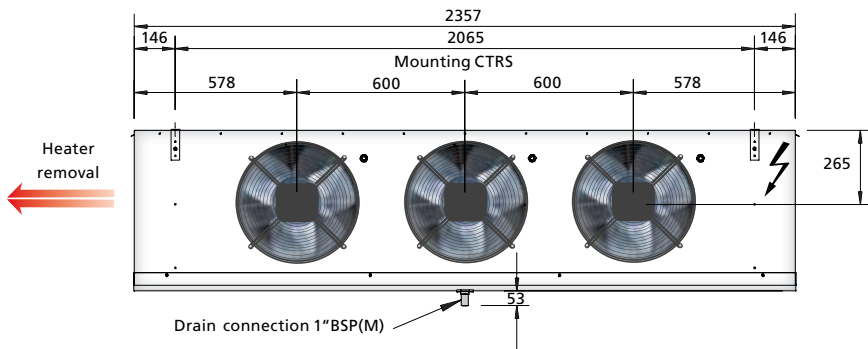

KMe 175

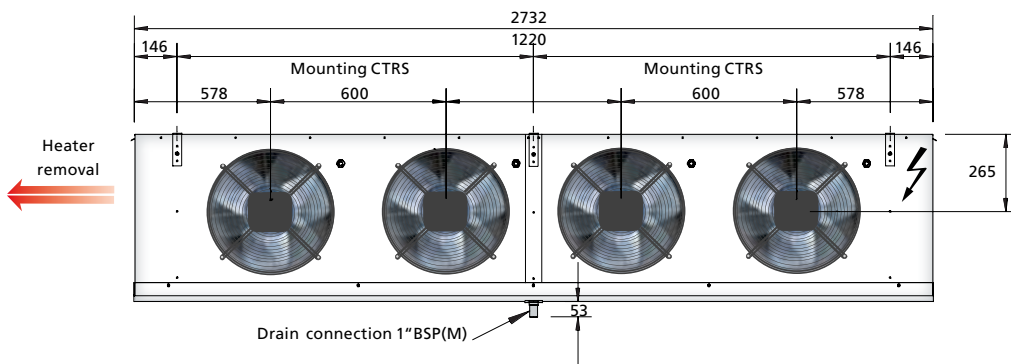

Note

All dimensions in mm

Engineered efficiency - no matter where or what



GEA Searle Ltd

20 Davis Way, Newgate Lane, Fareham, PO14 1AR
Tel. +44 (0) 1329 823344, Fax +44 (0) 1329 821242
sales@searle.co.uk, www.searle.co.uk

We reserve the right to change in whole or part, the specification detailed in this brochure without prior notice and, when necessary to achieve continuous production, to use alternative competitive designs of sub contract components made by various manufacturers.